



CPM/30

Struttura, coperchi e cestelli in acciaio inox - vasca in acciaio inox AISI316 spessore 15/10 - manici cestelli e pomelli coperchi in materiale isolante - resistenze corazzate in acciaio inox incoloy - rubinetto carico acqua collegabile alla rete - rubinetto di sicurezza esterno - camino rialzato con funzione paraspruzzi - il mod. CP/11 è da banco ed è dotato di sistema di scarico a innesto frontale a baionetta e coppia i cestelli piccoli - il mod. CPM/30 è dotato di mobile, ha sistema di scarico collegato alla rete e sistema a sfioramento per eliminare i residui di deposito di amido della pasta.

Optional: cestello grande per il mod. CP/11 - cestelli in varie dimensioni (CE 1/1 - 1/2 - 1/3 - 1/6) per il mod. CP/30.

Stainless steel structure. Lids and baskets - 15/10 thick AISI316 stainless steel container - insulating material basket handles and lid knobs - incoloy stainless steel armoured resistances - water supply faucet can be connected to the mains - external safety faucet - raised exhaust with spray guard function - mod. CP/11 is a counter model and comes with a frontal bayonet coupling drain system and pair of small containers - mod. CPM/30 comes with a trolley, has a drain system connected to the mains and skimming system to eliminate pasta starch deposits.

Optional: large basket for mod. CP/11 - various sized baskets (CE 1/1 - 1/2 - 1/3 - 1/6) for mod. CPM/30.

Structure, couvercles et paniers en acier inox - cuve en acier inox AISI316 épaisseur 15/10 - poignées paniers et couvercles en matière isolante - résistances blindées en acier inox incoloy - robinet de vidange d'eau raccordable au réseau - robinet de sécurité extérieur - cheminée surélevée servant de pare-gouttes - le mod. CP/11 est un modèle de comptoir et est muni de système de vidange à amorce frontale à baïonnette et paire de petits paniers - le mod. CPM/30 est accompagné d'un meuble. Il dispose d'un système de vidange raccordé au réseau et d'un système à effleurement pour éliminer les dépôts d'amidon des pâtes.

En option: grand panier pour le mod. CP/11 - paniers de diverses dimensions (CE 1/1 - 1/2 - 1/3 - 1/6) pour le mod. CPM/30.

Struktur, Deckel und Körbe aus Edelstahl - Becken aus AISI316-Edelstahl (Stärke 15/10) - Korbgriffe und Deckelknäufe aus Isoliermaterial - geschützte Widerstände aus Incoloy-Edelstahl - ans Wassernetz anschließbarer Wassereinfüllhahn - äußerer Sicherheitshahn - erhöhte Rückwand mit Spritzschutzfunktion - das Mod. CP/11 ist für einen Tresen vorgesehen und ist mit einem Ablasssystem mit Frontal-Bajonettverschluss ausgestattet und ein paar kleiner Körbe - das Mod. CPM/30 ist mit einem Möbelstück ausgestattet und verfügt über ein an das Wassernetz angeschlossenes Ablasssystem und ein Überlaufsystem zur Eliminierung von Nudelstärkeablageresten.

Optional: Grosser korb für das mod. CP/11 - Körbe in verschiedenen Größen (CE 1/1 - 1/2 - 1/3 - 1/6) für das mod. CPM/30.

Estructura, tapas y cestas de acero inoxidable - cubas de acero inoxidable AISI316 de 15/10 de espesor - mangos cestas y pomos tapas de material aislante - resistencias blindadas de acero inoxidable incoloy - grupo de carga agua para conectar a la red - grifo de seguridad externo - chimenea elevada para proteger de las salpicaduras - el mod. CP/11 es para banco y posee un sistema de descarga con acople frontal tipo bayoneta y par de cestos pequeños - el mod. CPM/30 con mueble en dotación, lleva un sistema de descarga conectado a la red y un sistema de extracción de la capa superficial para eliminar los depósitos de almidón de la pasta.

Optional: Cesto grande para el mod. CP/11 - cestas de diferentes tamaños (CE 1/1 - 1/2 - 1/3 - 1/6) para el mod. CPM/30.



Корпус, крышки и корзины из нержавеющей стали - емкость из нержавеющей стали AISI316 толщиной 15/10 - ручки корзин и крышек из изолирующего материала - армированные ТЭНы из нержавеющей стали "инколой" - кран для залива воды, подключаемый к водопроводной сети - внешний защитный кран - приподнятая вытяжная труба с функцией защиты от брызг - мод. CP/11 в настольном исполнении и оснащена системой выпуска с фронтальным байонетным соединением и две малых корзины - мод. CPM/30 оснащена тумбой, системой слива, подсоединенной к канализации и сенсорной системой очистки от крахмала.

Дополнительная комплектация: большая корзина для мод. CP/11 - корзины различных размеров (CE 1/1 - 1/2 - 1/3 - 1/6) для мод. CPM/30.



CP/11

MODELLO MODELE MODELO	MODEL MODELL МОДЕЛЬ	CP/11	CPM/30
POTENZA PUISSANCE POTENCIA	POWER LEISTUNG МОЩНОСТЬ	3,5 kW	8,0 kW
ALIMENTAZIONE BRANCHEMENT ALIMENTACIÓN	POWER SUPPLY STROMVERSORGUNG ПОДКЛЮЧЕНИЕ	230V/1N/50-60Hz	400V/3N/50-60Hz
CAPACITÀ VASCA BASIN CAPACITY CONTENANCE DE LA CUVE FASSUNGSVERMÖGEN DES BEHÄLTERS CAPACIDAD CUBA	ЕМКОСТЬ ВАННЫ	11 Lt.	30 Lt.
CAPACITÀ CESTO BASKET CAPACITY CONTENANCE PANIER KORB-FASSUNGSVERMÖGEN CAPACIDAD CESTA	ВМЕСТИМОСТЬ КОРЗИНЫ	1 kg	3 kg
TEMPO 20 → 100°C TEMPS 20 → 100°C TIEMPO 20 → 100°C	TIME 20 → 100°C ZEIT 20 → 100°C ВРЕМЯ 20 → 100°C	~ 20'	~ 30'
TEMPO 90 → 100°C TEMPS 90 → 100°C TIEMPO 90 → 100°C	TIME 90 → 100°C ZEIT 90 → 100°C ВРЕМЯ 90 → 100°C	~ 3'	~ 6'
PRODUZIONE ORARIA PRODUCTION PAR HEURE PRODUCCIÓN HORARIA	HOURLY PRODUCTION STUNDENLEISTUNG ПОЧАСОВОЕ ПРОИЗВОДСТВО	7 kg/h	15 kg/h
DIMENSIONI DIMENSIONS DIMENSIONES	DIMENSIONS ABMESSUNGEN РАЗМЕРЫ	300x600x 410h (mm)	400x700x 1040h (mm)
PESO NETTO POIDS NET PESO NETO	NET WEIGHT NETTOGEWICHT ВЕС НЕТТО	17 Kg	49 Kg
PESO LORDO POIDS BRUT PESO BRUTO	GROSS WEIGHT BRUTTOGEWICHT ВЕС БРУТТО	25 Kg	59 Kg
DIMENSIONI IMBALLO PACKAGED DIMENSIONS DIMENSIONS DE L'EMBALLAGE VERPACKUNGSABMESSUNGEN DIMENSIONES DEL EMBALAJE РАЗМЕРЫ УПАКОВКИ		660x370x 570h (mm)	780x480x 1200h (mm)
VOLUME IMBALLO PACKAGED VOLUME VOLUME DE L'EMBALLAGE VERPACKUNGSVOLUMEN VOLUMEN DEL EMBALAJE ОБЪЕМ УПАКОВКИ		0,139 m ³	0,449 m ³

CP/11

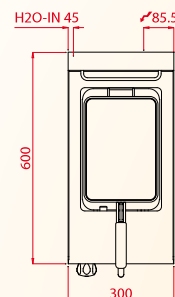
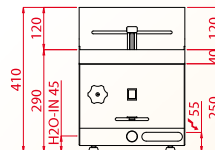

CPM30

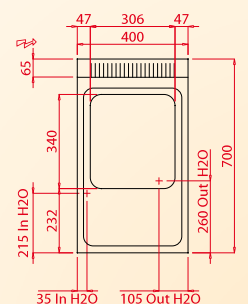
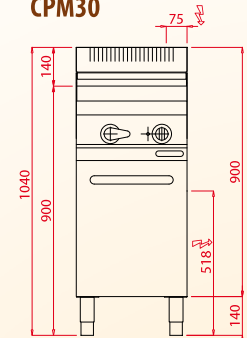



CUOCIPASTA ELETTRICI

ELECTRIC PASTA COOKERS
 CUISEURS DE PATES ELECTRIQUES
 ELEKTRONUDELKOCHER
 COCEDORES DE PASTA ELÉCTRICOS
 ЭЛЕКТРИЧЕСКИЕ МАКАРОНОВАРКИ

MODELLO MODELE MODELO	MODEL MODELL МОДЕЛЬ	CP/11 standard 2 basket	CP/11 optional 1 baskets	CESTELLO CE 1/1 solo / only CPM/30	CESTELLO CE 1/2 solo / only CPM/30	CESTELLO CE 1/3 solo / only CPM/30	CESTELLO CE 1/6 solo / only CPM/30
A		520 mm	520 mm	420 mm	550 mm	410 mm	195 mm
B		325 mm	325 mm	330 mm	330 mm	290 mm	140 mm
C		190 mm	190 mm	60x2 mm	220 mm	60x2 mm	60 mm
D		100 mm	210 mm	290 mm	140 mm	105 mm	105 mm
E		170 mm	170 mm	205 mm	205 mm	205 mm	205 mm
F		225 mm	225 mm	400 mm	380 mm	400 mm	400 mm
G		-	-	-	-	-	-
H		200 mm	200 mm	285 mm	285 mm	285 mm	285 mm
I		345 mm	345 mm	340 mm	340 mm	340 mm	340 mm
L		-	-	-	-	-	-
M		225 mm	225 mm	310 mm	310 mm	310 mm	310 mm

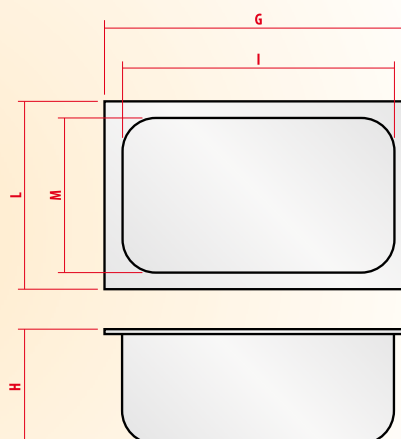
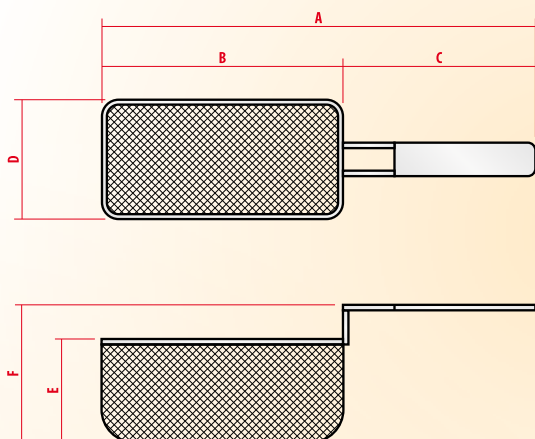

POSSIBILI COMBINAZIONI DEI CESTELLI / EXAMPLES OF BASKETS COMBINATIONS

CE 1/1	CE 1/2	CE 1/2	CE 1/3	CE 1/2	CE 1/6	CE 1/3		CE 1/3		CE 1/6	CE 1/6
			CE 1/3		CE 1/6	CE 1/3		CE 1/6	CE 1/6	CE 1/6	CE 1/6
			CE 1/3		CE 1/6	CE 1/6	CE 1/6	CE 1/6	CE 1/6	CE 1/6	CE 1/6

